



Tangential-flow hollow cone nozzles

Plastic version

Series 302

Uniform hollow cone spray.
Non-clogging nozzle, without swirl insert.

Applications:

Humidification of air in air washers, dust control, spraying onto filters, foam control, cooling.

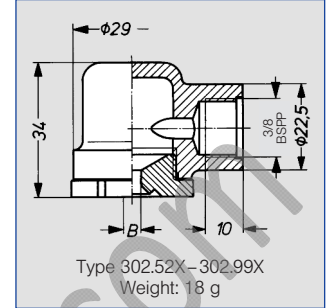
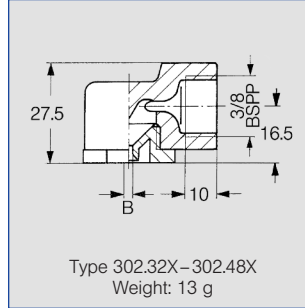

Spray angle	Ordering no.					B Ø [mm]	E Ø [mm]	V̇ [l/min]						Spray diameter D at p=2 bar	
	Type	Mat. no.			p [bar]						H = 250 mm	H = 500 mm			
		5E	51	53	0.5			1.0	2.0	[US gal./min] at 40 psi			3.0	5.0	10.0
		PVDF	PA	PP											
60°	302. 364	-	○	○	1.50	1.50	0.31	0.45	0.63	0.20	0.77	1.00	1.41	200	350
	302. 464	-	○	○	3.80	1.95	0.70	0.99	1.40	0.43	1.71	2.21	3.13	300	560
90°	302. 326	○	○	-	1.20	0.90	0.20	0.28	0.40	0.12	0.49	0.63	0.89	400	700
	302. 366	○	○	-	2.10	1.30	0.31	0.45	0.63	0.20	0.77	1.00	1.41	400	880
	302. 406	○	○	○	2.60	1.40	0.50	0.71	1.00	0.31	1.22	1.58	2.24	400	880
	302. 486	-	○	○	2.60	2.60	0.80	1.13	1.60	0.50	1.96	2.53	3.58	400	880
	302. 526	-	○	○	5.00	2.00	1.00	1.41	2.00	0.62	2.45	3.16	4.47	400	880
	302. 566	-	○	○	5.00	2.40	1.25	1.77	2.50	0.78	3.06	3.95	5.59	400	880
	302. 606	-	○	○	5.00	3.20	1.57	2.23	3.15	0.98	3.86	4.98	7.04	450	950
	302. 686	-	○	-	7.50	3.40	2.50	3.45	5.00	1.55	6.12	7.91	11.18	500	1050
	302. 766	-	○	-	9.00	4.30	4.00	5.66	8.00	2.48	9.80	12.65	17.89	500	1050
	302. 846	-	○	○	11.00	5.20	6.25	8.84	12.50	3.88	15.31	19.67	27.95	550	1130
130°	302. 328	○	-	-	1.35	0.80	0.20	0.28	0.40	0.12	0.49	0.63	0.89	700	1380
	302. 368	○	○	-	1.85	1.10	0.31	0.45	0.63	0.20	0.77	1.00	1.41	700	1380
	302. 408	○	○	-	3.65	1.30	0.50	0.71	1.00	0.31	1.22	1.58	2.24	700	1380
	302. 488	-	○	○	5.20	1.60	0.80	1.13	1.60	0.50	1.96	2.53	3.58	700	1380
	302. 528	-	○	-	5.00	2.00	1.00	1.41	2.00	0.62	2.45	3.16	4.47	700	1380
	302. 568	-	○	-	5.00	2.40	1.25	1.77	2.50	0.78	3.06	3.95	5.59	780	1520
	302. 608	○	○	○	5.00	3.20	1.57	2.23	3.15	0.98	3.86	4.98	7.04	780	1520
	302. 648	-	○	-	7.50	3.00	2.00	2.83	4.00	1.20	4.90	6.32	8.94	950	1850
	302. 688	-	○	-	7.50	3.40	2.50	3.54	5.00	1.55	6.12	7.91	11.18	950	1850
	302. 728	-	○	-	7.50	4.10	3.15	4.45	6.30	1.89	7.72	9.96	14.09	950	1850
302. 768	-	○	-	9.00	4.30	4.00	5.66	8.00	2.48	9.80	12.65	17.89	950	1850	
302. 848	-	○	-	11.00	5.20	6.25	8.84	12.50	3.88	15.31	19.76	27.95	950	1850	
302. 888	-	○	○	11.00	6.40	8.00	11.31	16.00	4.96	19.60	25.30	35.78	950	1850	
302. 968	○	○	-	11.00	8.60	12.50	17.68	25.00	7.75	30.62	39.53	55.90	950	1850	

B = bore diameter · E = narrowest free cross section

The folded page at the end of the catalogue will give you a survey on the various assembly possibilities.
For complete assembly accessories, please refer to »Accessories«.

Example for ordering	Type	+	Material no.	=	Ordering no.
	302. 364	+	51	=	302. 364. 51

Conversion formula for the above series: $\dot{V}_2 = \dot{V}_1 * \sqrt{\frac{p_2}{p_1}}$